



PRODUCT TECHNICAL SPECIFICATIONS

N°	TP-37
REV.	8
DATE:	18-11-14

PRODUCT:
MOBILE FIRE EXTINGUISHER 25 kg ABC POWDER

TYPE: MOBILE
EXTINGUISHER POWDER ABC
CODE: FI250

FEATURES:
Fire Extinguisher mobile dust permanently pressurized multipurpose in rechargeable steel cylinder.

SCHEMA:

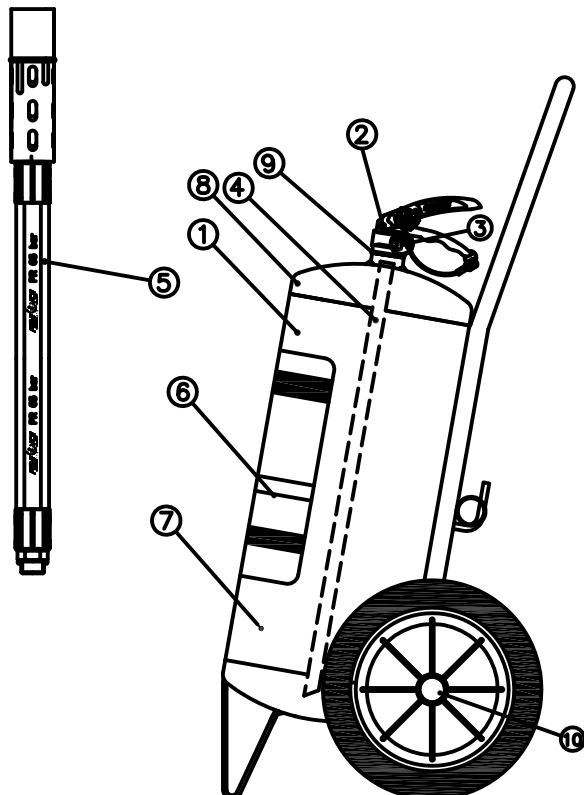

REGULATIONS AND REGISTERS

- Pressure Equipment Directive 97/23/EC;
- Pressure Equipment Regulations;
- Regulation of fire protection facilities;
- ES UNE-EN 1866;
- ES EN 615. Fire extinguishing media;
- ES EN 10130: Cold-rolled low carbon steel flat products;
- CE mark CE ;
- Quality assurance according EN ISO 9001;
- Mark product quality;
- Quality management system certificate.

TECHNICAL SPECIFICATIONS

Design pressure	25 bar
Test pressure	25 bar
Working pressure (20 °C)	17 bar
Fire rating (efficacy)	27A IIB
Load (tolerance: $\pm 2\%$)	25 kg
Working temperature	-20/60 °C
Propelling Load (tolerance: $\pm 10\%$)	320 g

DIMENSIONS

Height	978 mm
Diameter	250 mm
Nominal thickness	2,5 mm
Volume	29 liters
Tare(cylind, valv and syp tube)	20,77 kg
Total mass	46,03 kg

N°	SPARE PART NAME	MATERIALS	QUANT.
1	CYLINDER FI 250 (BOTTLE + CHASSIS)	Steel plate DC-04	1
2	VALVE FI 60	Brass, steel and rubber	1
3	GAUGE (ø 27 mm)	Chrome-plated brass	1
4	SYPHON TUBE FI 250	PVC	1
5	DIFUSSER HOSE FI 250	Rubber, textile, steel and polypropylene	1
6	LABEL FI 250	Silkscreen or adhesive acetate	1
7	EXTINGUISHER MEDIA	ABC multipurpose dry powder	25 kg
8	PROPELLANT	Dry nitrogen (N ₂)	320 g
9	CYLINDER SEAL FI 60	Elastomer	1
10	WAGON WHEEL ø300mm FI 251	Polypropylene and synthetic rubber	2

SAFETY DEVICES:
Safety pin in handle of operation;
Safety seal in safety pin.

COMMENTS:
Suitable for: A, B and C fire. (Also with presence of electrical tension);
It must not be used in D fires or reactive material (Na, K, Mg);
Painting 100% polyester powder polymerized in oven, red color RAL 3000;
The instructions of use and maintenance must be consulted.

FIRE ICE, S.L.
Políg. Ind. de Castellanos, parc. 302; CASTELLANOS DE MORISCOS 37439
(Salamanca) ESPAÑA (SPAIN) Tif 34-923361557, Fax 34-923361394

PREPARED:
A. G. REDONDO.

APPROVED:
J. CASTILLA C.